

SECTION **FL**
FUEL SYSTEM

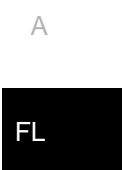

CONTENTS

PRECAUTION	2	Removal and Installation	6
PRECAUTIONS	2	Disassembly and Assembly	9
Precaution for Battery Service	2	Inspection	10
General Precautions	2	FUEL TANK	11
PREPARATION	3	Exploded View	11
PREPARATION	3	Removal and Installation	11
Commercial Service Tools	3	Inspection	13
PERIODIC MAINTENANCE	4	EVAP CANISTER	14
FUEL SYSTEM	4	Exploded View	14
Inspection	4	Removal and Installation	14
Quick Connector	4	Disassembly and Assembly	14
REMOVAL AND INSTALLATION	5	Inspection	15
FUEL LEVEL SENSOR UNIT, FUEL FILTER		SERVICE DATA AND SPECIFICATIONS	
AND FUEL PUMP ASSEMBLY	5	(SDS)	16
Exploded View	5	SERVICE DATA AND SPECIFICATIONS	
		(SDS)	16
		Fuel Tank	16

A
 C
 D
 E
 F
 G
 H
 I
 J
 K
 L
 M
 N
 O
 P

PRECAUTIONS

< PRECAUTION >

PRECAUTION

PRECAUTIONS

Precaution for Battery Service

INFOID:000000007472470

Before disconnecting the battery, lower both the driver and passenger windows. This will prevent any interference between the window edge and the vehicle when the door is opened/closed. During normal operation, the window slightly raises and lowers automatically to prevent any window to vehicle interference. The automatic window function will not work with the battery disconnected.

General Precautions

INFOID:000000007472471

WARNING:

When replacing fuel line parts, be sure to observe the following.

- Put a “CAUTION: FLAMMABLE” sign in the workshop.
- Be sure to work in a well ventilated area and furnish workshop with a CO2 fire extinguisher.
- Never smoke while servicing fuel system. Keep open flames and sparks away from the work area.

CAUTION:

- Use gasoline required by the regulations for octane number. Refer to [GI-33, "Fuel"](#).
- Before removing fuel line parts, perform out the following procedures:
 - Put drained fuel in an explosion-proof container and put the lid on securely. Keep the container in safe area.
 - Release fuel pressure from the fuel lines. Refer to [EC-616, "Inspection"](#).
 - Disconnect the battery cable from the negative terminal.
- Always replace O-ring and clamps with new ones.
- Never kink or twist tubes when they are being installed.
- Never tighten hose clamps excessively to avoid damaging hoses.
- After installing tubes, check there is no fuel leakage at connections in the following steps.
 - Apply fuel pressure to fuel lines with turning ignition switch “ON” (with engine stopped). Then check for fuel leakage at connections.
 - Start engine and rev it up and check for fuel leakage at connections.
- Use only a genuine NISSAN fuel filler cap as a replacement. If an incorrect fuel filler cap is used, the “MIL” may come on.
- For servicing “On Board Refueling Vapor Recovery (ORVR)” parts, refer to [EC-543, "Description"](#).

PREPARATION

< PREPARATION >

PREPARATION

PREPARATION

Commercial Service Tools

INFOID:000000007472472

A

FL

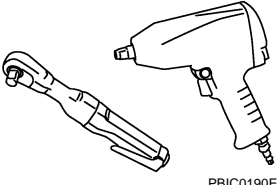
Tool name	Description
Power tool  PBIC0190E	Loosening nuts and bolts

C

D

E

F

G

H

I

J

K

L

M

N

O

P

FUEL SYSTEM

< PERIODIC MAINTENANCE >

PERIODIC MAINTENANCE

FUEL SYSTEM

Inspection

INFOID:000000007472473

Inspect fuel lines, fuel filler cap and fuel tank for improper attachment, leakage, cracks, damage, loose connections, chafing or deterioration.

- A : Engine
- B : Fuel line
- C : Fuel tank

If necessary, repair or replace damaged parts.

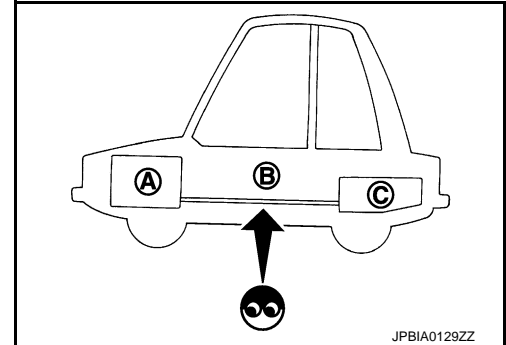

Quick Connector

INFOID:000000007472474

CAUTION:

- After connecting fuel tube quick connectors, check quick connectors are secure.

- 1 : Quick connector
- 2 : Retainer
- A : Hard tube (or the equivalent)
- B : Connection (cross-section)
- C : Resin tube
- D : To under floor fuel line
- E : To fuel tank
- F : Tab
- G : Disconnection

- Ensure that connector and resin tube never contact any adjacent parts.

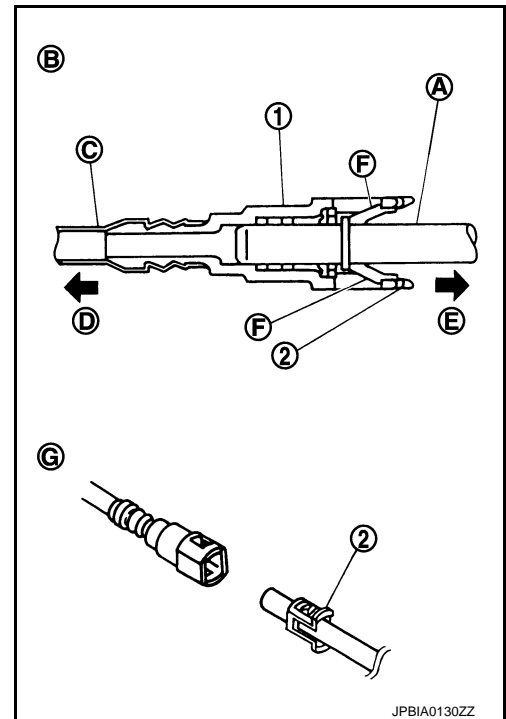

FUEL LEVEL SENSOR UNIT, FUEL FILTER AND FUEL PUMP ASSEMBLY

< REMOVAL AND INSTALLATION >

REMOVAL AND INSTALLATION

FUEL LEVEL SENSOR UNIT, FUEL FILTER AND FUEL PUMP ASSEMBLY

Exploded View

INFOID:000000007472475

A

FL

REMOVAL

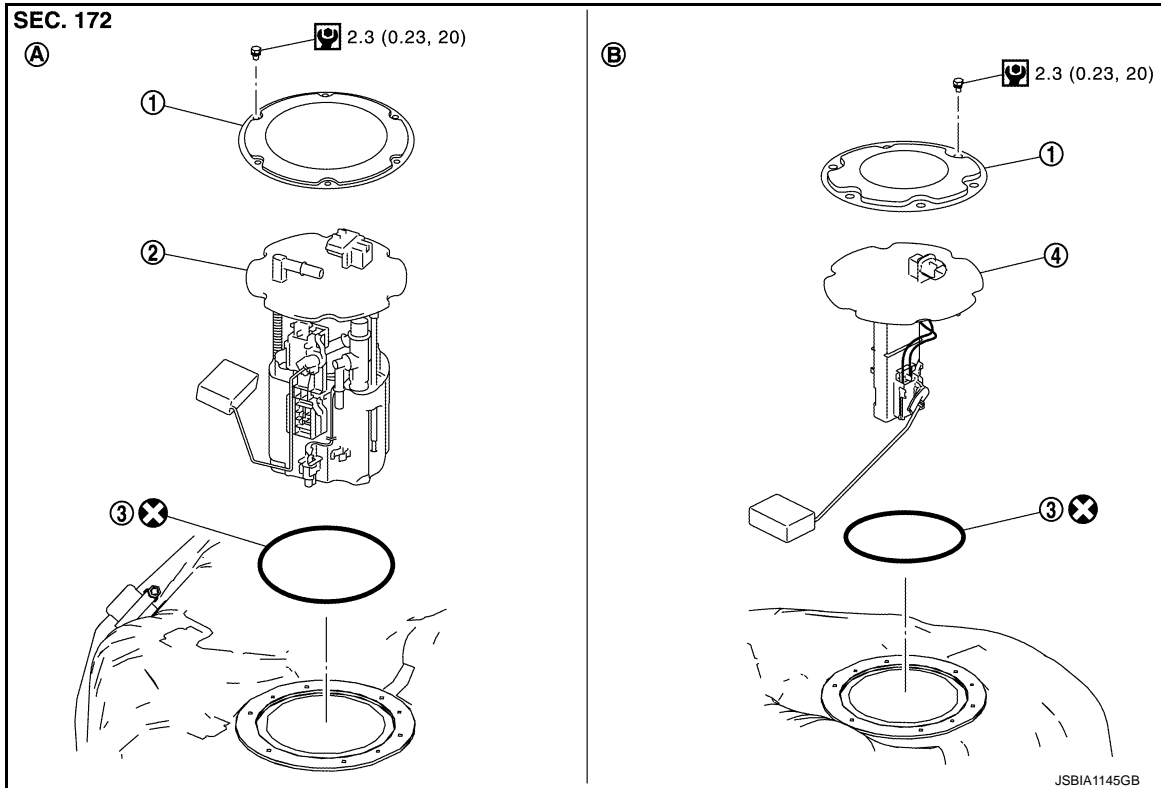

- 1. Retainer
 - 2. Main fuel level sensor unit, fuel filter and fuel pump assembly
 - 3. O-ring
 - 4. Sub fuel level sensor unit
- A. Right side B. Left side

Refer to [GI-4, "Components"](#) for symbols in the figure.

DISASSEMBLY

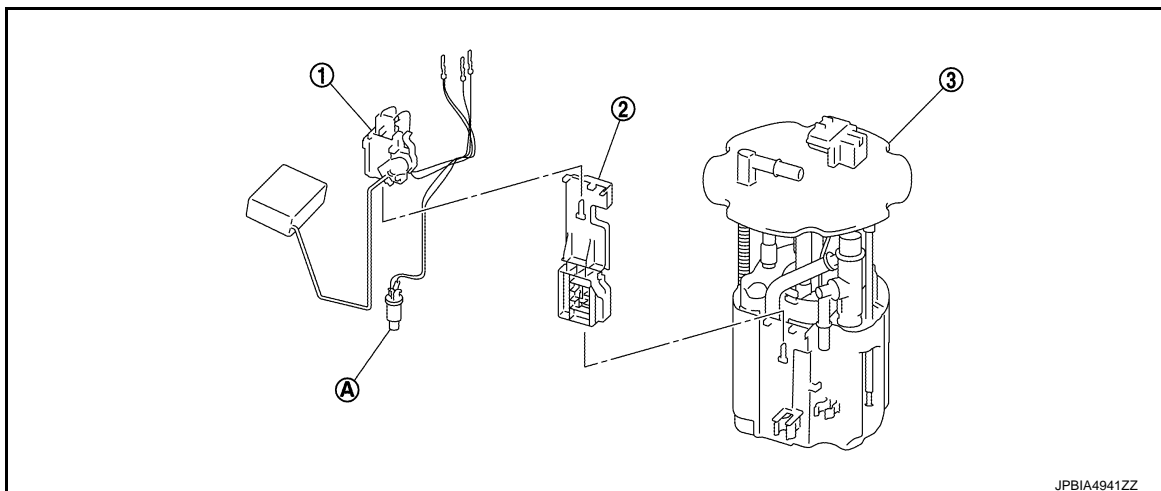

C

D

E

F

G

H

I

J

K

L

M

N

O

P

FUEL LEVEL SENSOR UNIT, FUEL FILTER AND FUEL PUMP ASSEMBLY

< REMOVAL AND INSTALLATION >

1. Main fuel level sensor unit
 2. Adapter
 3. Fuel filter and fuel pump assembly
- A. Fuel tank temperature sensor

Removal and Installation

INFOID:000000007472476

WARNING:

Read "General Precautions" when working on the fuel system. Refer to [GI-29, "General Precautions"](#).

REMOVAL

1. Check fuel level on fuel gauge. If fuel gauge indicates more than the level as shown in the figure (full or almost full), drain fuel from fuel tank until fuel gauge indicates level as shown in the figure or below.

NOTE:

The above instructions must be followed since fuel spills when removing the fuel level sensor unit if the fuel level exceeds the mounting surface.

- As a guide, fuel level becomes the position as shown in the figure or below when approximately 20 ℓ (5-1/4 US gal, 4-3/8 Imp gal) of fuel are drained from fuel tank.
 - In a case that fuel pump does not operate, perform the following procedure.
- a. Insert hose of less than 22 mm (0.87 in) in diameter into fuel filler tube through fuel filler opening to draw fuel from fuel filler tube.
 - b. Disconnect fuel filler hose from fuel filler tube. Refer to [FL-11, "Exploded View"](#).
 - c. Insert fuel tube into fuel tank through fuel filler hose to draw fuel from fuel tank.
2. Release the fuel pressure from the fuel lines. Refer to [EC-616, "Inspection"](#).
 3. Open fuel filler lid.
 4. Open filler cap and release the pressure inside fuel tank.
 5. Remove rear seat cushion. Refer to [SE-176, "Exploded View"](#).
 6. Peel off floor carpet, then remove inspection hole cover (1) units by turning clips (2) clockwise by 90 degrees.

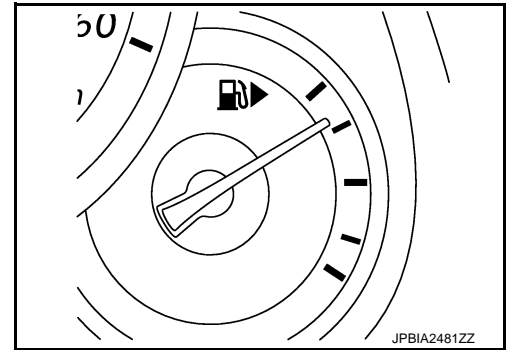

A : Direction mark

b : 90°

⇐ : Vehicle front

Right side : Main fuel level sensor unit, fuel filter and fuel pump assembly

Left side : Sub fuel level sensor unit

7. Disconnect harness connector (3) and fuel feed tube (2).

1 : Quick connector

⇐ : Vehicle front

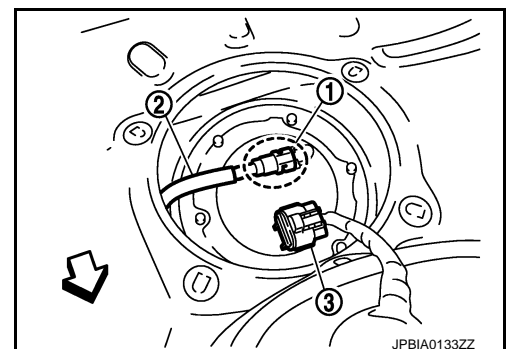
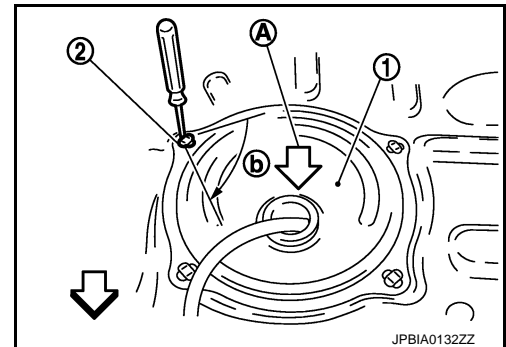

Disconnect quick connector as follows:

FUEL LEVEL SENSOR UNIT, FUEL FILTER AND FUEL PUMP ASSEMBLY

< REMOVAL AND INSTALLATION >

- Hold the sides of connector, push in tabs and pull out fuel feed tube.

A : Pull
B : Push in tabs

- If quick connector sticks to tube of main fuel level sensor unit, push and pull quick connector several times until they start to move. Then disconnect them by pulling.

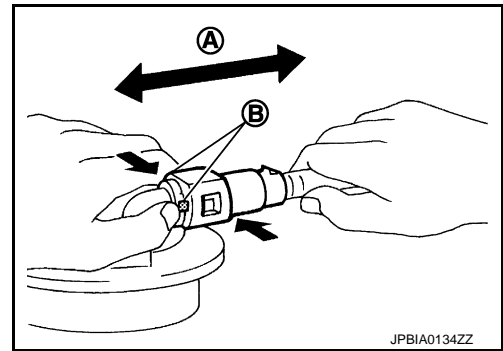

CAUTION:

- Quick connector (1) can be disconnected when the tabs (F) are completely depressed. Never twist it more than necessary.

B : Connection (Cross-section)
D : To under floor fuel line
E : To fuel tank
G : Disconnection

- Never use any tools to disconnected quick connector.
- Keep resin tube (C) away from heat. Be especially careful when welding near the resin tube.
- Prevent acid liquid such as battery electrolyte, etc. from getting on resin tube.
- Never bend or twist resin tube during installation and disconnection.
- Never remove the remaining retainer (2) on hard tube (or the equivalent) (A) except when resin tube or retainer is replaced.
- When resin tube or hard tube (or the equivalent) is replaced, also replace retainer with new one.

Retainer color : Natural

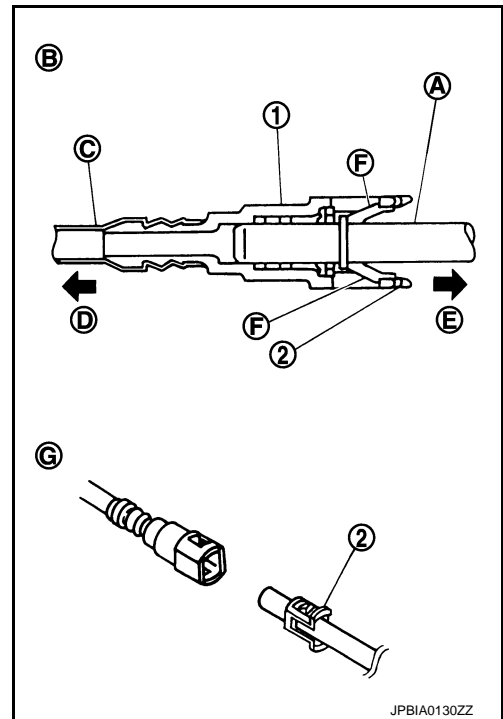

- To keep the connecting portion clean and to avoid damage and foreign materials, cover them completely with plastic bags (A) or something similar.

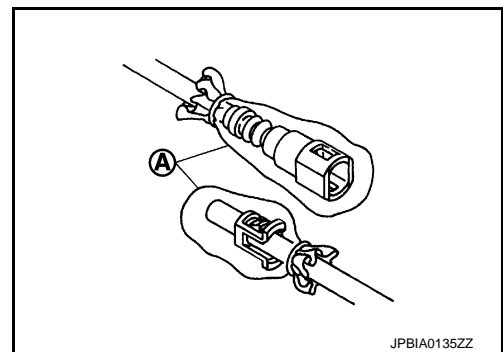

- Remove main fuel level sensor unit, fuel filter and fuel pump assembly, and sub fuel level sensor unit as follows:

CAUTION:

- Never bend float arm during removal.
- Avoid impacts such as falling when handling components.

- Removal of main fuel level sensor unit, fuel filter and fuel pump assembly:

- Remove retainer.
- Raise main fuel level sensor unit, fuel filter and fuel pump assembly, and disconnect quick connector as follows:

FUEL LEVEL SENSOR UNIT, FUEL FILTER AND FUEL PUMP ASSEMBLY

< REMOVAL AND INSTALLATION >

- Push in tabs (1) and pull out fuel tube (2).
- b. Removal of sub fuel level sensor unit:
 - i. Remove retainer.
 - ii. Raise and release sub fuel level sensor unit to remove.

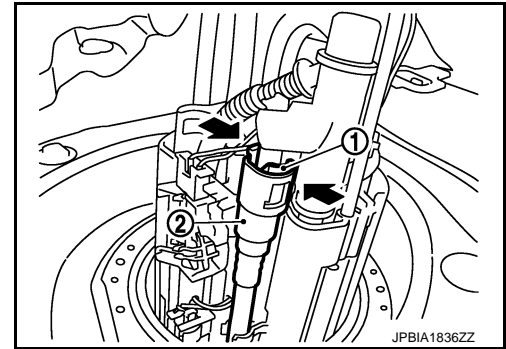

INSTALLATION

Note the following, and install in the reverse order of removal.

CAUTION:

Do not reuse O-rings.

Fuel hose

- When installing fuel hose connector (1), refer to “Quick Connector”.

2 : Retainer

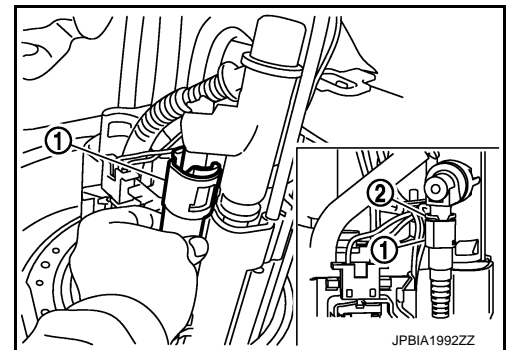

Main and Sub Fuel Level Sensor Unit

- Face main and sub fuel level sensor units as shown in the figure, and install them with the knock pin (C) on back aligned with pin hole on fuel tank.

A : Right side

B : Left side

↔ : Vehicle front

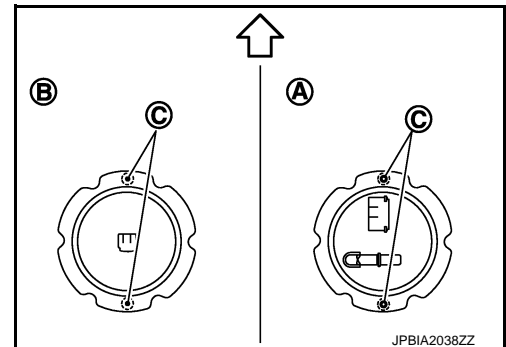

- Install retainer so that its notch becomes parallel with the notch on fuel tank.

A : Align notches

↔ : Vehicle front

- Tighten retainer mounting bolts evenly.

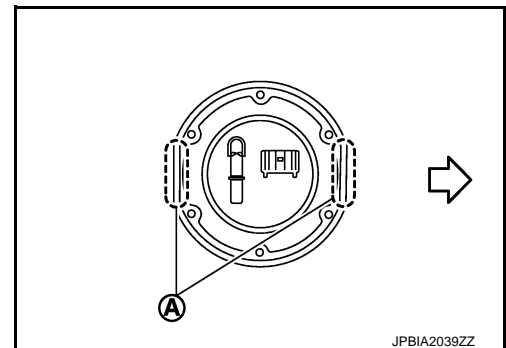

Quick Connector

- Connect quick connector as follows:

1. Check the connection for damage or any foreign materials.

FUEL LEVEL SENSOR UNIT, FUEL FILTER AND FUEL PUMP ASSEMBLY

< REMOVAL AND INSTALLATION >

- Align the connector with the tube, then insert the connector straight into the tube until a click sound is heard.
- After connecting, check that the connection is secure by following method.
 - Pull the tube and the connector to check they are securely connected.

A : Pull

- Visually confirm that the two retainer tabs are connected to the connector.

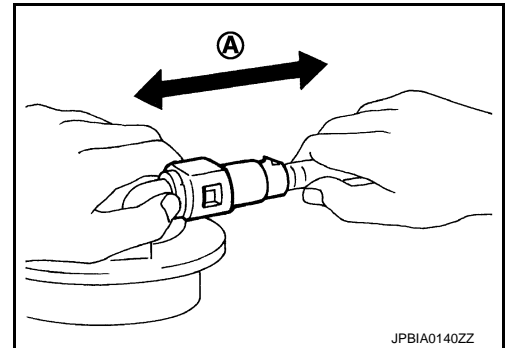

INFOID:000000007472477

Disassembly and Assembly

DISASSEMBLY

CAUTION:

Sub fuel level sensor unit cannot be disassembled and should be replaced as a unit.

Remove main fuel level sensor unit as follows:

- Disconnect harness connector (A).
 - Hold connector by fingers and push stopper release tab.
 - Pull it out connector.

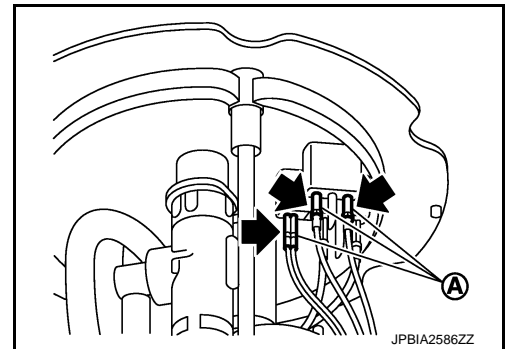

- Remove main fuel level sensor unit (1) from adapter (2) as follows:

3 :Fuel filter and fuel pump assembly

- Push in tab (A) to release the lock.
- After fixing tabs are disengaged, slide main fuel level sensor unit out in direction shown by the arrow (B).

CAUTION:

- Be careful not to damage the main fuel level sensor unit.
- Never disassemble fuel filter and fuel pump assembly.

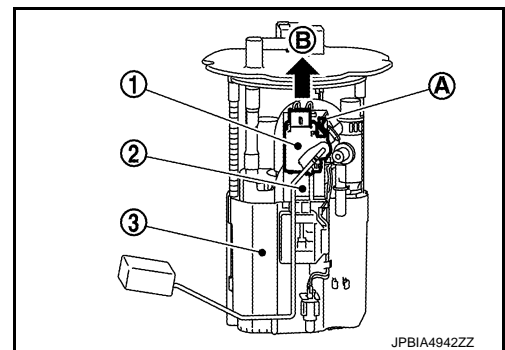

- Remove adapter from the fuel filter and fuel pump assembly, if necessary, in the same procedure used in removing main fuel level sensor unit.

ASSEMBLY

CAUTION:

Sub fuel level sensor unit cannot be disassembled and should be replaced as a unit.

- Check for damage of main fuel level sensor unit installation position on the side of fuel filter and fuel pump assembly.
- Slide main fuel level sensor unit until it aligns to installation groove, then insert it until it stops.
 - After inserting, apply force in reverse direction (removal direction) to ensure it cannot be pulled out.

FUEL LEVEL SENSOR UNIT, FUEL FILTER AND FUEL PUMP ASSEMBLY

< REMOVAL AND INSTALLATION >

3. Connect the white (A), black (B), and red (C) harnesses so that they are in the positions shown in the figure.
 - Securely insert harness connector until it stops.

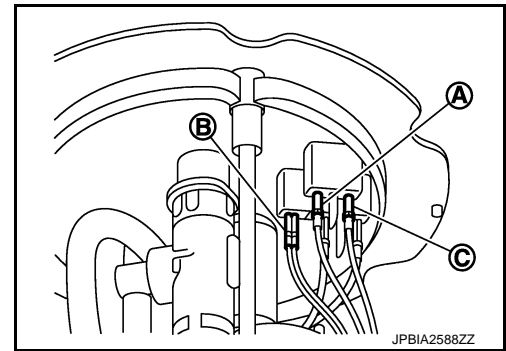

Inspection

INFOID:000000007472478

INSPECTION AFTER INSTALLATION

Use the following procedure to check for fuel leakage.

1. Turn ignition switch "ON" (with engine stopped), then check connections for leakage by applying fuel pressure to fuel piping.
2. Start engine and let it idle and check there are no fuel leakage at the fuel system connections.

FUEL TANK

< REMOVAL AND INSTALLATION >

FUEL TANK

Exploded View

INFOID:000000007472479

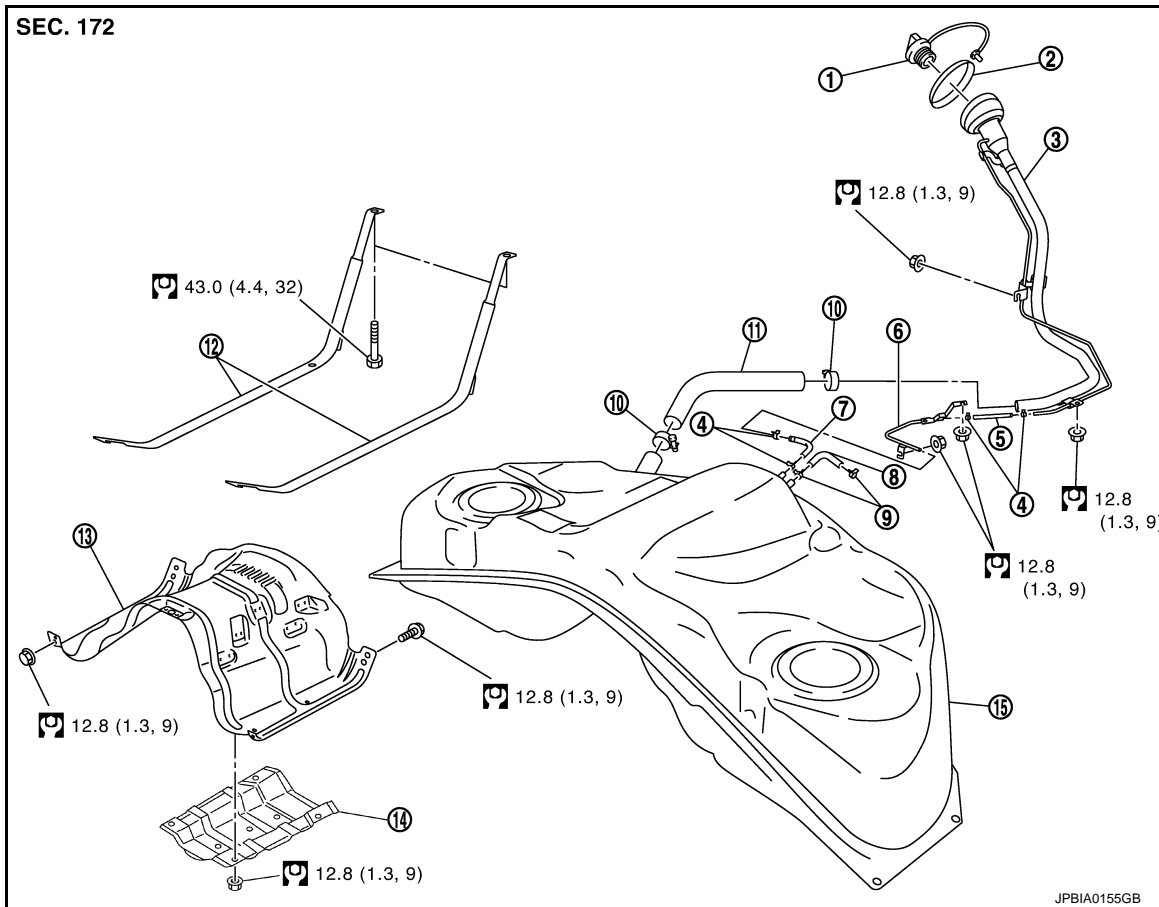

- | | | |
|-------------------------|----------------------|-----------------------------|
| 1. Fuel filler cap | 2. Grommet | 3. Fuel filler tube |
| 4. Clamp | 5. Vent hose | 6. Vent tube |
| 7. Vent hose | 8. EVAP hose | 9. Clamp |
| 10. Clamp | 11. Fuel filler hose | 12. Fuel tank mounting band |
| 13. Fuel tank protector | 14. Insulator | 15. Fuel tank |

Refer to [GI-4, "Components"](#) for to symbols in the figure.

Removal and Installation

INFOID:000000007472480

WARNING:

Be sure to read "General Precautions" when working on the fuel system. Refer to [GI-29, "General Precautions"](#).

REMOVAL

- Drain fuel from fuel tank if necessary. Refer to [FL-11, "Exploded View"](#).
 - Perform work on level place.
1. Perform steps 2 to 7 of "REMOVAL" in "FUEL LEVEL SENSOR UNIT, FUEL FILTER AND FUEL PUMP ASSEMBLY" on main and sub fuel level sensor units. Refer to [FL-5, "Exploded View"](#).
 2. Remove exhaust front tube, center muffler, and main muffler. Refer to [EX-5, "Exploded View"](#).
 3. Remove propeller shaft. Refer to [DLN-88, "Exploded View"](#) (M/T models) or [DLN-96, "Exploded View"](#) (A/T models).
 4. Remove parking rear brake cables. Refer to [PB-6, "PEDAL TYPE : Exploded View"](#) (PEDAL TYPE) or [PB-7, "LEVER TYPE : Exploded View"](#) (LEVER TYPE).

FUEL TANK

< REMOVAL AND INSTALLATION >

5. Remove rear suspension assembly. Refer to [RSU-22. "Exploded View"](#).

NOTE:

For this service, drive shaft, final drive, and rear suspension member are required not to be separate one another during removal.

6. Disconnect fuel filler hose (1), vent hose (2), and EVAP hoses (3) at fuel tank side.

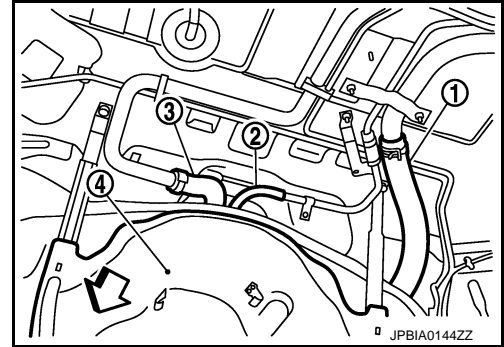

4 : Fuel tank protector

↔ : Vehicle front

7. Remove fuel tank protector.

8. Support the lower part of fuel tank (1) with transmission jack (A).

CAUTION:

Support the position that fuel tank mounting bands never engage.

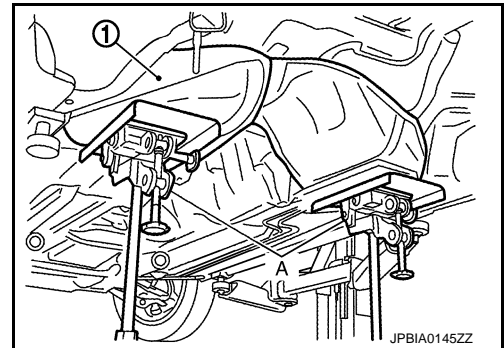

9. Remove fuel tank mounting bands.

10. Supporting with hands, descend transmission jack carefully, and remove fuel tank.

CAUTION:

- Check that all connection points have been disconnected.
- Confirm there is no interference with vehicle.

11. Remove fuel filler tube if necessary.

INSTALLATION

Note the following, and install in the reverse order of removal.

- Surely clamp fuel hoses and insert hose to the length below.

Fuel filler hose : 35 mm (1.38 in)

The other hoses : 25 mm (0.98 in)

- Be sure hose clamp is not placed on swelled area of fuel tube.
- Tighten the clamp hand with the top mark (A) until the mark is on the bolt head flange.

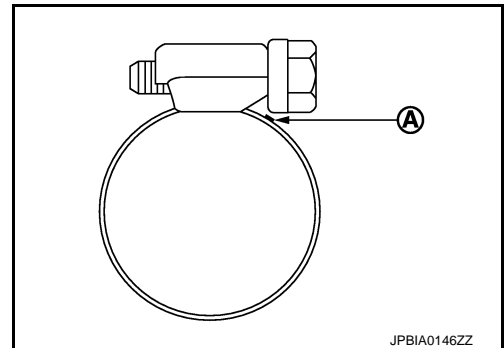

- To connect quick connector, refer to [FL-4. "Quick Connector"](#).

FUEL TANK

< REMOVAL AND INSTALLATION >

Inspection

INFOID:000000007472481

A

INSPECTION AFTER INSTALLATION

Use the following procedure to check for fuel leakage.

1. Turn ignition switch "ON" (with engine stopped), and check connections for leakage by applying fuel pressure to fuel piping.
 2. Start engine and rev it up and check there are no fuel leakage at the fuel system tube and hose connections.
- After removing/installing rear suspension assembly, check to adjust wheel alignment and then, adjust neutral position of steering angle sensor. Refer to [RSU-6. "Inspection"](#) and [STC-25. "4WAS FRONT ACTUATOR NEUTRAL POSITION ADJUSTMENT : Description"](#).

FL

C

D

E

F

G

H

I

J

K

L

M

N

O

P

EVAP CANISTER

< REMOVAL AND INSTALLATION >

EVAP CANISTER

Exploded View

INFOID:000000007472482

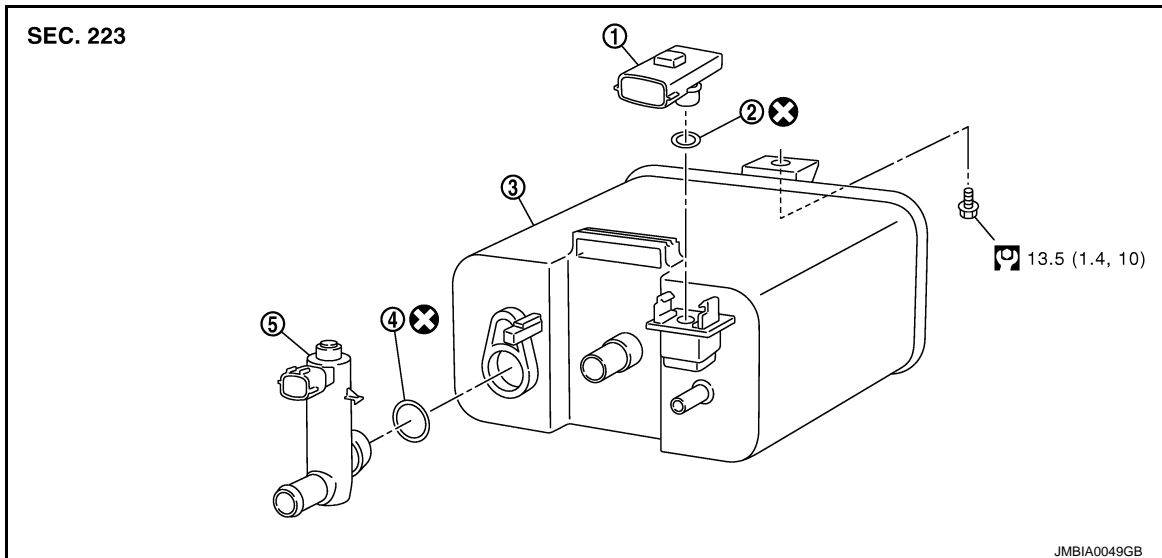

1. EVAP canister system pressure sensor 2. O-ring 3. EVAP canister
4. O-ring 5. EVAP canister vent control valve

Refer to [GI-3, "Contents"](#) for symbols not described on the above.

Removal and Installation

INFOID:000000007794771

REMOVAL

1. Lift up the vehicle.
2. Remove EVAP canister fixing bolt.
3. Remove EVAP canister.

NOTE:

The EVAP canister vent control valve and EVAP canister system pressure sensor can be removed without removing the EVAP canister.

INSTALLATION

Install in the reverse order of removal.

NOTE:

Tighten EVAP canister fixing bolt to the specified torque.

Disassembly and Assembly

INFOID:000000007472483

DISASSEMBLY

1. Turn EVAP canister vent control valve counterclockwise.

- A : Lock
B : Unlock

2. Remove the EVAP canister vent control valve.

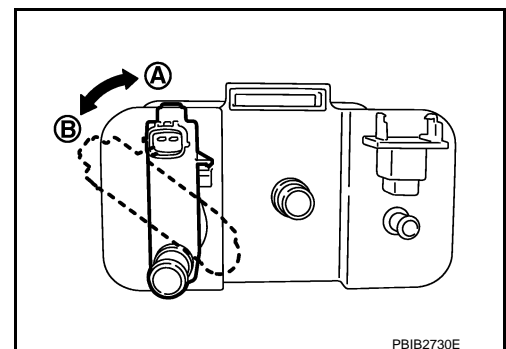

EVAP CANISTER

< REMOVAL AND INSTALLATION >

ASSEMBLY

Assemble in the reverse order of disassembly.

CAUTION:

Do not reuse O-rings.

Inspection

INFOID:000000007472484

Check EVAP canister as follows:

1. Block port (B).
2. Blow air into port (A) and check that it flows freely out of port (C).
3. Release blocked port (B).
4. Apply vacuum pressure to port (B) and check that vacuum pressure exists at the ports (A) and (C).
5. Block port (A) and (B).
6. Apply pressure to port (C) and check that there is no leakage.

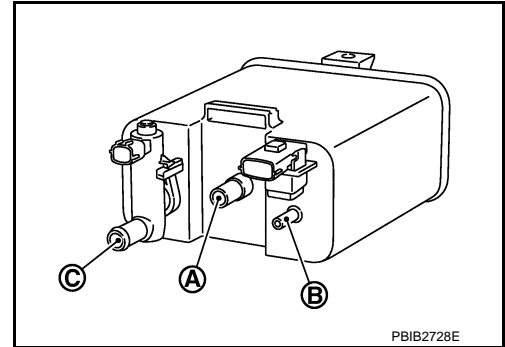

A

FL

C

D

E

F

G

H

I

J

K

L

M

N

O

P

SERVICE DATA AND SPECIFICATIONS (SDS)

< SERVICE DATA AND SPECIFICATIONS (SDS)

SERVICE DATA AND SPECIFICATIONS (SDS)

SERVICE DATA AND SPECIFICATIONS (SDS)

Fuel Tank

INFOID:000000007472485

Standard and Limit

Fuel tank capacity	Approx. 75.6 ℓ (20 US gal, 16-5/8 Imp gal)
Fuel recommendation	Refer to GI-33